

# Installation Guide

## Network Camera

Model No. **K-EF235L01E/K-EW215L01E**

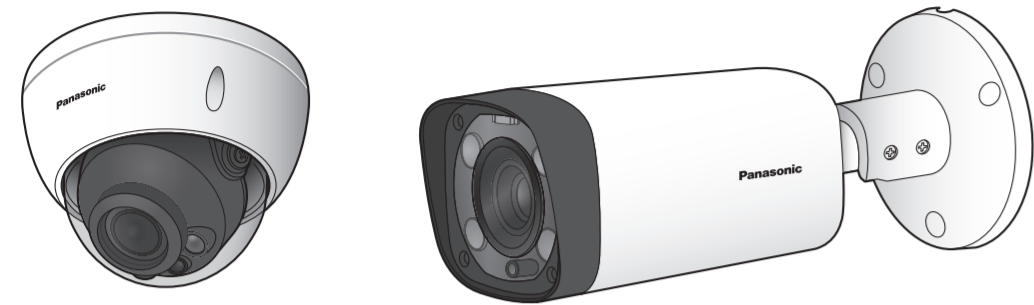

K-EF235L01E  
(Dome type)

K-EW215L01E  
(Bullet type)

- For information about how to perform the settings and how to operate the camera, refer to the operation manual on the provided DVD-ROM.
- Before attempting to connect or operate this product, please read these instructions carefully and save this manual for future use.
- microSDXC/microSDHC/microSD memory card is described as microSD memory card or SD memory card.

Panasonic Corporation  
http://www.panasonic.com

Panasonic i-PRO Sensing Solutions Co., Ltd.  
Fukuoka, Japan

Authorised Representative in EU:

Panasonic Testing Centre  
Panasonic Marketing Europe GmbH  
Winsbergring 15, 22525 Hamburg, Germany



© Panasonic i-PRO Sensing Solutions Co., Ltd. 2019

avDu0918-1109 PGQX2263YA  
Printed in China

### WARNING:

- To prevent injury, this apparatus must be securely attached to the wall/ceiling in accordance with the installation instructions.
- To prevent fire or electric shock hazard, do not expose this apparatus to rain or moisture. (Dome type only)
- The apparatus should not be exposed to dripping or splashing. (Dome type only)
- All work related to the installation of this product should be made by qualified service personnel or system installers.
- The installation shall be carried out in accordance with all applicable installation rules.
- The connections should comply with local electrical code.
- Batteries (battery pack or batteries installed) shall not be exposed to excessive heat such as sunlight, fire or the like.

### CAUTION:

- The network camera is only intended for a connection to an ethernet or PoE network without routing to the outside plant.

### Disposal of Old Equipment and Batteries Only for European Union and countries with recycling systems

These symbols on the products, packaging, and/or accompanying documents mean that used electrical and electronic products and batteries must not be mixed with general household waste.

For proper treatment, recovery and recycling of old products and used batteries, please take them to applicable collection points in accordance with your national legislation.

By disposing of them correctly, you will help to save valuable resources and prevent any potential negative effects on human health and the environment.

For more information about collection and recycling, please contact your local municipality.

Penalties may be applicable for incorrect disposal of this waste, in accordance with national legislation.

### Note for the battery symbol (bottom symbol)

This symbol might be used in combination with a chemical symbol. In this case it complies with the requirement set by the Directive for the chemical involved.

: Direct current symbol

## Important safety instructions

- Read these instructions.
- Keep these instructions.
- Heed all warnings.
- Follow all instructions.
- Do not use this apparatus near water. (Dome type only)
- Clean only with dry cloth. (Dome type only)
- Do not install near any heat sources such as radiators, heat registers, stoves, or other apparatus (including amplifiers) that produce heat.
- Only use attachments/accessories specified by the manufacturer.
- Unplug this apparatus during lightning storms or when unused for long periods of time.
- Refer all servicing to qualified service personnel. Servicing is required when the apparatus has been damaged in any way, such as power-supply cord or plug is damaged, liquid has been spilled or objects have fallen into the apparatus, the apparatus has been exposed to rain or moisture, does not operate normally, or has been dropped.

## Main functions

- 2-megapixel Full-HD vari-focal network camera**
- H.265 & H.264 dual-stream encoding**  
H.265 outputs and H.264 outputs can be provided.
- Wide-angle lens with day/night functionality and built-in IR-LED**

## Limitation of liability

THIS PUBLICATION IS PROVIDED "AS IS" WITHOUT WARRANTY OF ANY KIND, EITHER EXPRESS OR IMPLIED, INCLUDING BUT NOT LIMITED TO, THE IMPLIED WARRANTIES OF MERCHANTABILITY, FITNESS FOR ANY PARTICULAR PURPOSE, OR NON-INFRINGEMENT OF THE THIRD PARTY'S RIGHT. THIS PUBLICATION COULD INCLUDE TECHNICAL INACCURACIES OR TYPOGRAPHICAL ERRORS. CHANGES ARE ADDED TO THE INFORMATION HEREIN, AT ANY TIME, FOR THE IMPROVEMENTS OF THIS PUBLICATION AND/OR THE CORRESPONDING PRODUCT (S).

## Disclaimer of warranty

IN NO EVENT SHALL Panasonic i-PRO Sensing Solutions Co., Ltd. BE LIABLE TO ANY PARTY OR ANY PERSON, EXCEPT FOR REPLACEMENT OR REASONABLE MAINTENANCE OF THE PRODUCT, FOR THE CASES, INCLUDING BUT NOT LIMITED TO BELOW:

- ANY LOSS OR DAMAGE, INCLUDING WITHOUT LIMITATION, DIRECT OR INDIRECT, SPECIAL, CONSEQUENTIAL OR EXEMPLARY, ARISING OUT OF OR RELATING TO THE PRODUCT;
- ANY INCONVENIENCE, LOSS, OR DAMAGE CAUSED BY INAPPROPRIATE USE OR NEGLIGENCE OPERATION OF THE USER;
- ALL MALFUNCTIONS OR TROUBLES FROM UNAUTHORIZED DISASSEMBLE, REPAIR OR MODIFICATION OF THE PRODUCT BY THE USER, REGARDLESS OF THE CAUSE OF THE MALFUNCTION OR TROUBLE;
- INCONVENIENCE OR ANY LOSS ARISING WHEN IMAGES ARE NOT DISPLAYED, DUE TO ANY REASON OR CAUSE INCLUDING ANY FAILURE OR PROBLEM OF THE PRODUCT;
- ANY PROBLEM, CONSEQUENTIAL INCONVENIENCE, OR LOSS OR DAMAGE, ARISING OUT OF THE SYSTEM COMBINED BY THE DEVICES OF THIRD PARTY;
- ANY CLAIM OR ACTION FOR DAMAGES BROUGHT BY ANY PERSON OR ORGANIZATION AS A PHOTOGRAPHED SUBJECT DUE TO VIOLATION OF PRIVACY CONCERNING A SURVEILLANCE CAMERA'S PICTURE OR SAVED DATA, FOR SOME REASON (INCLUDING USE WHEN USER AUTHENTICATION ON THE AUTHENTICATION SETTING SCREEN IS SET TO OFF), BECOMING PUBLIC OR BEING USED FOR ANY PURPOSE;
- LOSS OF REGISTERED DATA CAUSED BY ANY FAILURE (INCLUDING INITIALIZATION OF THE PRODUCT DUE TO FORGOTTEN AUTHENTICATION INFORMATION SUCH AS A USER NAME AND PASSWORD).

## Open Source Software

- This product contains open source software licensed under GPL (GNU General Public License), LGPL (GNU Lesser General Public License), etc.
- Customers can duplicate, distribute and modify the source code of the software under license of GPL and/or LGPL.
- Refer to the "readme.txt" file on the provided DVD-ROM for further information about open source software licenses and the source code.
- Please note that Panasonic shall not respond to any inquiries regarding the contents of the source code.

## Copyright

Except for open source software licensed under GPL/LGPL and so on, distributing, copying, disassembling, reverse compiling and reverse engineering of the software provided with this product are all expressly prohibited. In addition, exporting any software provided with this product violating export laws is prohibited.

## Network security

As you will use this unit connected to a network, your attention is called to the following security risks.

- Leakage or theft of information through this unit
- Use of this unit for illegal operations by persons with malicious intent
- Interference with or stoppage of this unit by persons with malicious intent

It is your responsibility to take precautions such as those described below to protect yourself against the above network security risks.

- Use this unit in a network secured by a firewall, etc.
- If this unit is connected to a network that includes PCs, make sure that the system is not infected by computer viruses or other malicious entities (using a regularly updated anti-virus program, anti-spyware program, etc.).
- To prevent unauthorized access, use user-authentication, set user names and passwords, and limit which users can log in.
- Apply measures such as user authentication to protect your network against leakage or theft of information, including image data, authentication information (user names and passwords), alarm mail information, FTP server information and DDNS server information.
- After the unit is accessed by the administrator, make sure to close the browser.
- Change the administrator password periodically. Additionally, save user authentication information (user names and passwords) in such a way that it is kept out of the hands of third parties.
- Do not install the camera in locations where the camera or the cables can be destroyed or damaged by persons with malicious intent.

## Precautions

### WARNING

- Refer installation work to the dealer.**  
Installation work requires technique and experience. Failure to observe this may cause fire, electric shock, injury, or damage to the product.
  - Be sure to consult the dealer.
- Turn the power off when do wiring of this product.**  
Failure to observe this may cause electric shock. In addition, short circuit or wrong wiring may cause fire.
- Correctly perform all wiring.**  
Short circuits in the wiring or incorrect wiring may cause fire or electrical shock.
- Stop the operation immediately when something is wrong with this product.**  
When smoke goes up from the product, the smell of smoke comes from the product, or the exterior of the product has deteriorated, continued use will cause a fire or fall of the product resulting in injury, or damage to the product.
  - In this case, turn the power off immediately and contact qualified service personnel for service.
- Select an installation area that can support the total weight.**  
Selecting an inappropriate installation surface may cause this product to fall down or topple over, resulting in injury or accidents.
  - Installation work shall be started after sufficient reinforcement.
- Install the product securely on a wall or a ceiling in accordance with the installation instructions.**  
Failure to observe this may cause injury or accidents.
- Periodic inspections shall be conducted.**  
Rust on the metal parts or screws may cause a fall of the product resulting in injury or accidents.
  - Consult the dealer for the inspections.
- Do not install this product in locations subject to vibration.**  
Loosening of mounting screws or bolts may cause a fall of the product resulting in injury or accidents.
- Install this product in a location high enough to avoid people and objects from bumping the product.**  
Failure to observe this may cause injury.
- Do not attempt to disassemble or modify this product.**  
Failure to observe this may cause fire or electric shock. Consult the dealer for the repair or inspections.
- The screws and bolts must be tightened to the specified torque.**  
Failure to observe this may cause a drop resulting in injury or accidents.
- Do not insert any foreign objects.**  
Fire or electrical shock may be caused if water or any foreign objects, such as metal objects, enter inside the unit. Turn the power off immediately and contact qualified service personnel for service.
- Do not use this product in an inflammable atmosphere.**  
Failure to observe this may cause an explosion resulting in injury.
- Avoid installing this product in the locations where salt damage occurs or corrosive gas is produced.**  
Otherwise, the mounting portions will deteriorate and accidents such as a fall of the product may occur.
- Do not strike or give a strong shock to this product.**  
Failure to observe this may cause fire or injury.
- Do not hang down from this product or use this product as a pedestal.**  
Failure to observe this may cause a drop resulting in accidents.
- Do not damage the power cable.**  
Do not damage, fabricate, twist, stretch, bundle, or forcibly bend the power cable. Do not place heavy objects on it, and keep it away from heat sources.  
Use of a damaged power cable may cause electric shock, short circuit, or fire.  
Consult the dealer for repair.
- Do not install or clean the camera, or touch this product, the power cable or the connected cables during thunder storms.**  
Failure to observe this may cause electric shock.
- Keep micro SD memory cards away from infants and children.**  
Otherwise, they may swallow the cards by mistake. In this case, consult a doctor immediately.

### CAUTION

- Turn the power off when cleaning this product.**  
Failure to observe this may cause injury.

## Precautions for use

### This product has no power switch.

When turning off the power, disconnect the power supply from the 12 V DC power supply or the PoE device.

### To keep on using with stable performance

Do not use this camera in hot and humid conditions for a long time. Failure to observe this causes component degradation resulting in life shortening of this product. Do not expose this camera to direct heat sources such as a heater.

### Do not touch the lens with your bare hands.

A dirty lens causes deterioration of picture quality.

### Handle this camera with care.

Do not drop this camera, nor apply shock or vibration to this camera. Failure to observe this may cause trouble. If a strong shock or vibration is applied to the enclosure, it may cause damage or allow water to enter this product.

### About the battery

A battery is installed inside the camera. Do not leave the battery exposed in environments of excessive heat as a result of sunlight or fire.

### Product disposal/transfer

Data saved on this product or a storage device used with this product may lead to personal information leakage. When it is necessary to dispose or give this product to someone, even when for repair, make sure that there is no data on this product. When abandoning the memory media, it is recommended to destroy it physically after deleting data by PC.

### Cleaning this product body

Be sure to turn off the power before cleaning. Failure to observe this may cause injury. Do not use benzine, thinner, alcohol, or any other types of solvents or detergents. Otherwise, it may cause discoloration. When using a chemical cloth for cleaning, read the caution provided with the chemical cloth product.

### About the CMOS image sensor

- When continuously shooting a bright light source such as a spotlight, the color filter of the CMOS image sensor may have deteriorated and it may cause discoloration. Even when changing the fixed shooting direction after continuously shooting a spotlight for a certain period, the discoloration may remain.
- When shooting fast-moving subjects or performing panning/tilting operations, objects crossing the shooting area may look to be bending askew.

### AVC Patent Portfolio License

THIS PRODUCT IS LICENSED UNDER THE AVC PATENT PORTFOLIO LICENSE FOR THE PERSONAL USE OF A CONSUMER OR OTHER USES IN WHICH IT DOES NOT RECEIVE REMUNERATION TO

- ENCODE VIDEO IN COMPLIANCE WITH THE AVC STANDARD ("AVC VIDEO") AND/OR
- DECODE AVC VIDEO THAT WAS ENCODED BY A CONSUMER ENGAGED IN A PERSONAL ACTIVITY AND/OR WAS OBTAINED FROM A VIDEO PROVIDER LICENSED TO PROVIDE AVC VIDEO. NO LICENSE IS GRANTED OR SHALL BE IMPLIED FOR ANY OTHER USE. ADDITIONAL INFORMATION MAY BE OBTAINED FROM MPEG LA, L.L.C. SEE HTTP://WWW.MPEGLA.COM

### Equipment classification and power source indication label

Refer to the indication label on the bottom side of this unit for the equipment classification, power source, and other information.

## Specifications

● Basic	K-EF235L01E	K-EW215L01E
Power source:*	12 V DC, PoE (IEEE802.3af compliant)	
Power consumption:*	12 V DC: 750 mA/Approx. 9 W PoE 48 V DC: 190 mA/Approx. 9 W (Class 0 device)	12 V DC: 1.1 A/Approx. 12.9 W PoE 48 V DC: 270 mA/Approx. 12.9 W (Class 0 device)
Operating environment Ambient operating temperature: Ambient operating humidity:	-30 °C to +60 °C [-22 °F to 140 °F], 10 % to 90 % (no condensation)	
Storage environment Storage temperature: Storage humidity:	-30 °C to +60 °C [-22 °F to 140 °F] 10 % to 95 % (no condensation)	
Waterproof:	Main body: IP66	
Shock resistance:	Compliant with IK10 (IEC62262)	Not supported
Dimensions:	ø122 mm × 89 mm (H) {ø4-13/16 inches × 3-1/2 inches (H)}	ø90 mm × 213 mm (D) {ø3-17/32 inches × 8-3/8 inches (H)} (Camera front view: 80 mm (W) × 72 mm (H) {3-5/32 inches (W) × 2-27/32 inches (H)})
Mass:	Approx. 400 g {0.88 lbs}	Approx. 690 g {1.52 lbs}

\* Refer to our website (http://security.panasonic.com/support/info\_d/index.html) for further information about Power source and Power consumption.

### ● Camera

Image sensor:	Approx. 1/2.8" type CMOS image sensor	
Effective pixels:	Approx. 2 megapixels	
Scanning system:	Progressive	
Minimum illumination:	0.2 lx / F1.4 (Color)*, 0 lx / F1.4 (IR on) * [Image Adjust] Shutter: (0-)80 ms, Gain: (0-)100"	
Gain:	Auto/ Manual	
Back light compensation:	BLC/ HLC/ WDR	
Shutter speed:	Auto/ Manual, 1/3 sec to 1/100000 sec	
Day/Night:	Auto/ Color/ BW	
IR LED Light:	Distance up to 30 m (98 ft)	Distance up to 60 m (197 ft)
White balance:	Auto/ Natural/ Street Lamp/ Outdoor/ Manual/ Regional Custom	
Digital noise reduction:	3D DNR ON/ OFF	
Privacy masking:	On/ Off (4 Zone, Rectangle)	
Video Motion Detection (VMD):	On/ Off (4 Area)	
Image rotation	0 °/ 90 °/ 180 °/ 270 °	

### ● Lens

Zoom ratio:	5x Optical (Motorized zoom/ Motorized focus)	
Focal length:	2.7 to 13.5 mm	
Aperture:	1 : 1.4	
Angular field of view:	H : 106 ° (WIDE) to 29 ° (TELE)	V : 57 ° (WIDE) to 17 ° (TELE)

### ● Network

Network:	10BASE-T/ 100BASE-TX, RJ45 connector	
Resolution:	1080P (1920x1080)/ 1.3 M (1280x960)/ 720P (1280x720)/ D1 (704x480)/ VGA (640x480)/ CIF (352x240)	
Image compression method:†1	H.264H/ H.265/ MJPEG	
Frame Rate:	1 to 30 fps	
Protocol:	HTTP, TCP, ARP, RTSP, RTP, UDP, RTCP, SMTP, FTP, DHCP, DNS, DDNS, PPOPE, IPv4/v6, QoS, UPnP, NTP	
Maximum concurrent access number:	20 Users (Number of sessions that can connect to cameras at the same time)	
OS:	Microsoft Windows 10 Microsoft Windows 8.1 Microsoft Windows 7	
Browser:	Windows Internet Explorer 11	
Compatible micro SD memory card:‡2 †3	4 to 64 GB	

†1 Two streams can be transmitted individually.

‡2 When repeatedly recording images on a micro SD memory card using the auto overwrite function, make sure to use a micro SD memory card with high reliability and durability.

†3 Use the micro SD memory card that complies with UHS-1 (Ultra High Speed-1) in the case of SD Speed Class 10.

## Trademarks and registered trademarks

- Microsoft, Windows, Windows Media, Internet Explorer, and ActiveX are either registered trademarks or trademarks of Microsoft Corporation in the United States and/or other countries.
- Microsoft product screen shot(s) reprinted with permission from Microsoft Corporation.
- All other trademarks identified herein are the property of their respective owners.

## Standard accessories

Confirm the following items are included in the camera's packaging.

Installation Guide (this document) .....	1 pc.	Template .....	1 pc.
RJ45 waterproof connector cover .....	1 pc.	DVD-ROM .....	1 pc.
.....	1 package	Torx wrench .....	1 pc.

## Connection

### Device external cable

You can refer to the following figure for cable information.

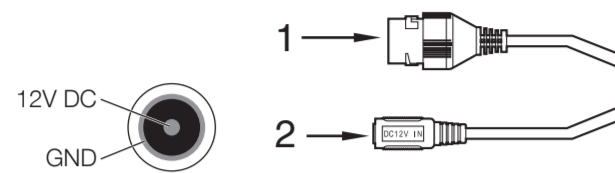

- LAN (Network port) .....RJ45 waterproof jack. Connect to standard Ethernet cable.

#### NOTE:

Some devices do not support PoE power supply.

- 12V DC (Power input port).....Power port. Input 12V DC. When a PoE power supply is used to power the camera, the power input port is not used. Process the jack as indicated below.

#### <Dome type>

Protect the jack with tape or the like to prevent dust and moisture from collecting inside.

#### <Bullet type>

Appropriate waterproof treatment is performed.

### Assembling RJ45 waterproof connector

#### IMPORTANT:

- The maximum cable length is 100 m.
- Make sure that the PoE device in use is compliant with IEEE802.3af standard.
- Use all 4 pairs (8 pins) of the Ethernet cable.
- The external dimensions of the Ethernet cable are  $\phi 5$  mm to  $\phi 6.5$  mm.
- If the procedure for the RJ45 waterproof connector part is not correctly followed, the waterproofing may be compromised. Do not install the camera where the RJ45 waterproof connector is exposed to constant rain or moisture.

- Attach the rubber ring (accessory) to the RJ45 waterproof jack connected to the camera as shown.
  - Attach with the flat surface of the rubber ring facing the RJ45 waterproof jack.

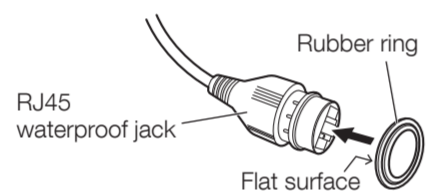

- First, pass the Ethernet cable through the RJ45 waterproof connector cap (accessory), the inner rubber (accessory) and then RJ45 waterproof connector cover (accessory). Next, use a specialized tool (locally procured) to crimp the RJ45 plug (locally procured) to the end of the Ethernet cable.
  - Pass the inner rubber over the cable so that the grooved surface faces the RJ45 plug and the flat surface faces the Ethernet cable.

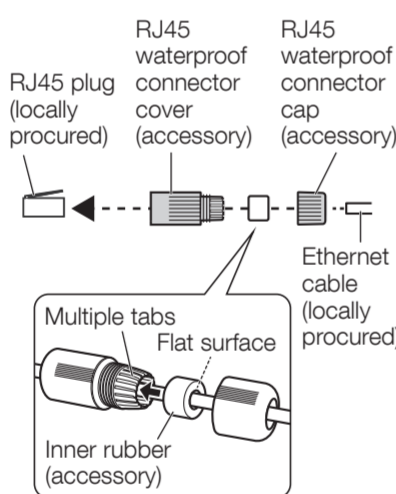

The following steps illustrate how to attach the connector to a camera as it is being installed.

- Connect the RJ45 plug to the RJ45 waterproof jack and then rotate and tighten firmly the RJ45 waterproof connector cover.
- Connect the RJ45 waterproof connector cap to the RJ45 waterproof connector cover and rotate the RJ45 waterproof connector cap until there is no gap between it and the RJ45 waterproof connector cover.

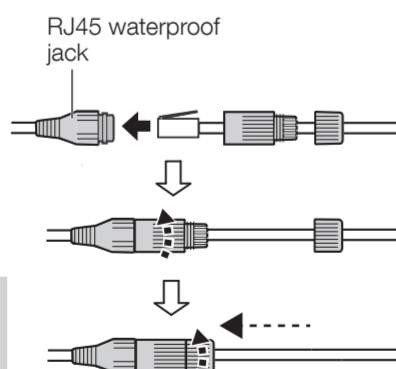

#### IMPORTANT:

When removing the RJ45 waterproof connector, be sure to loosen the RJ45 waterproof connector cap first, rotate the RJ45 waterproof connector cover in the direction opposite to the attaching direction, and remove it. Otherwise the RJ45 waterproof jack may be damaged.

### Connect 12 V DC AC adaptor to the power port (if necessary)

When the camera will run on an external power supply, use an AC adaptor that can provide a 12 V DC 1.5 A or higher power supply.

#### IMPORTANT:

When cables are used outdoors, there is a chance that they may be affected by lightning. In such a case, install a lightning arrester close to the camera, and make the length of the network cable between the camera and lightning arrester as short as possible to prevent the camera from being damaged by lightning.

#### CAUTION:

- A READILY ACCESSIBLE DISCONNECT DEVICE SHALL BE INCORPORATED TO THE EQUIPMENT POWERED BY 12 V DC POWER SUPPLY.
- ONLY CONNECT 12 V DC CLASS 2 POWER SUPPLY (UL1310/CSA 223) or LIMITED POWER SOURCE (IEC/EN/UL/CSA 60950-1).

## K-EF235L01E

### Framework and dimension

Please refer to the following figure for dimension information.

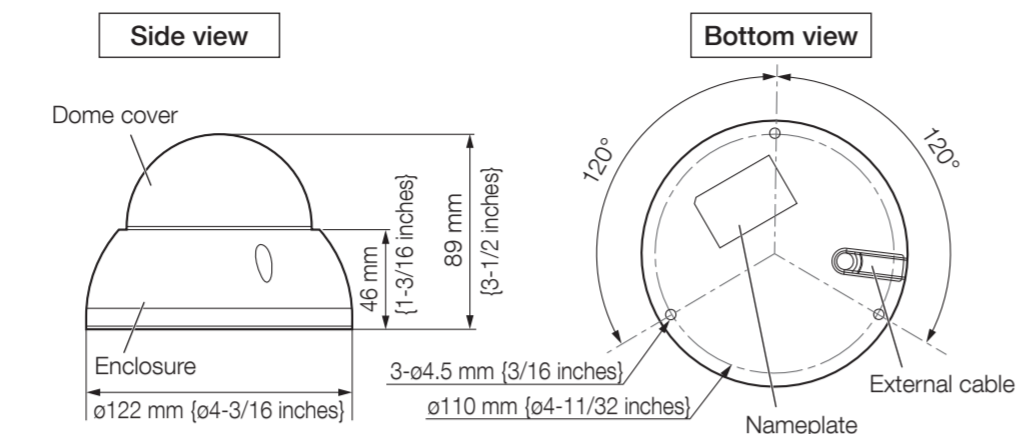

### Device Installation

Secure the camera with screws (3 pcs.) (M4: locally procured).

#### IMPORTANT:

- Before starting the connection, turn off the power of the devices to be connected.
- Procure screws (3 pcs.) to secure the camera to a ceiling or a wall, according to the material of the installation area. In this case, wood screws and nails should not be used.
- Required pull-out capacity of a single screw or anker is 196 N {20 kgf} or more.

#### Step 1 Open a hole for installing and cabling the camera on the ceiling or wall.

Pick out the template from the carton box and use it to open holes in the positions for installation screws and the wiring opening to pass cabling through.

#### NOTE:

- The position of the Panasonic logo when the enclosure is attached is roughly halfway between the mounting holes. Orient the template to match the desired logo position.
- Determine the screw hole diameter based on screw specifications.
- To run cabling or make connections behind a ceiling or wall, drill a hole in the wiring opening position indicated on the template. If it is necessary to run the cabling to the side, it can be arranged in the side wiring direction shown on the template. Orient the template to match the desired wiring direction.

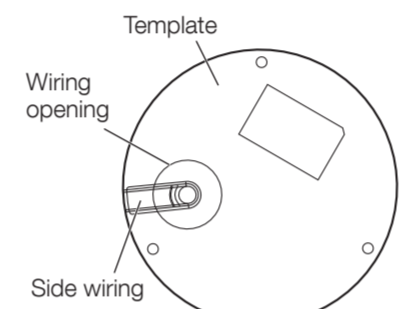

#### Step 2 Remove the enclosure from the camera.

Use the torx wrench (accessory) to loosen the three enclosure fixing screws. Then remove the enclosure from the camera.

#### Step 3 If necessary, install a micro SD memory card in the camera.

- Confirm the position of the micro SD memory card socket.
- Tilt the camera slightly on the tilt axis as shown in the figure to create an opening to access the micro SD memory card socket.
- Slide the cover of the micro SD memory card socket and raise it as shown in the figure.
- Place the micro SD memory card in the slot, close the cover, and slide it back to its original position to secure the micro SD memory card.

#### NOTE:

- Be careful not to touch the wiring portion of the circuit board when you raise the cover of the micro SD memory card socket.
- Insert the micro SD memory card with the side with printing facing up.

#### Step 4 Connect the camera.

Connect the RJ45 waterproof connector to the camera's RJ45 waterproof jack. (Refer to steps 4 and 5 in "Assembling RJ45 waterproof connector".) If necessary, also connect the plug of an AC adaptor for 12 V DC power to the power port.

#### Step 5 Attach the camera to the ceiling or wall.

Attach the camera using the three screws (M4: locally procured) on the ceiling or wall.

#### NOTE:

- Required pull-out capacity of a single screw or anker is 196 N {20 kgf} or more.
- After connection, push extra cabling through the hole in the ceiling or wall to adjust the length.

#### Step 6 Turn the power on and check the screen on the computer.

Turn on power from the 12 V DC power supply or PoE device and operate the camera. Check video from the camera on the computer screen and refer to "Network Configuration" on the right side of this document.

#### Step 7 Adjust the camera angle.

Adjust the camera angle by moving it on the PAN, TILT, and YAW axes as you check the video on the computer screen.

#### Step 8 Attach the enclosure.

Use the torx wrench (accessory) to tighten the three enclosure fixing screws to secure the enclosure on the camera. Finally, remove the protective sheet. (Recommended tightening torque: 0.8 N·m {8.0 kgf·cm})

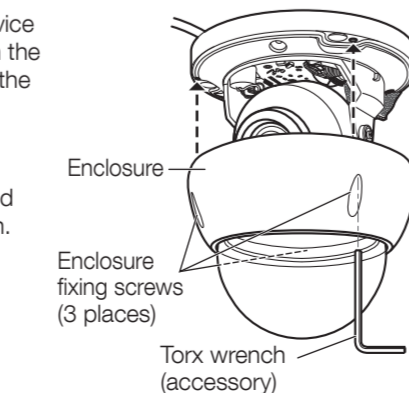
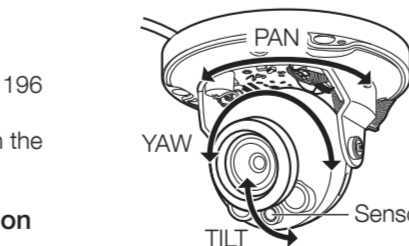
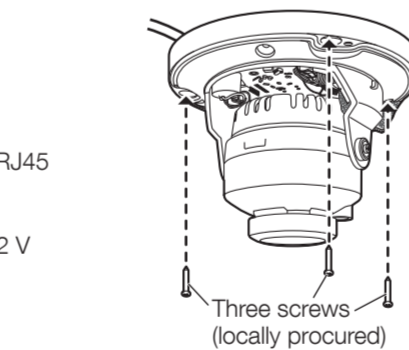
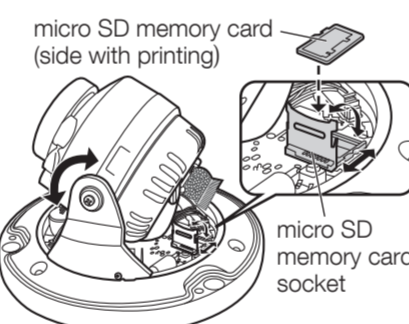
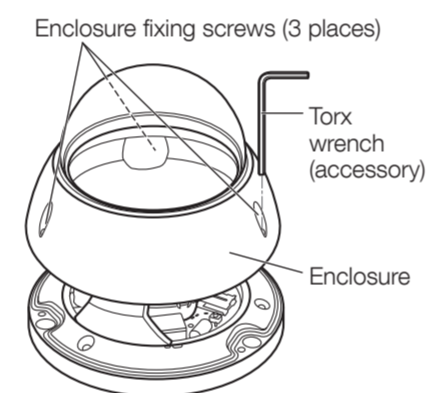

## K-EW215L01E

### Framework and dimension

Please refer to the following figure for dimension information.

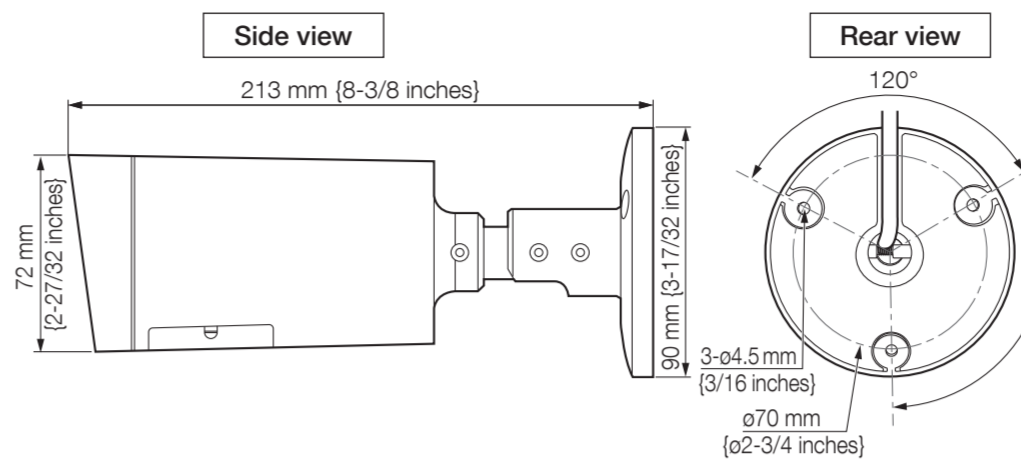

### Device Installation

Secure the camera with screws (3 pcs.) (M4: locally procured).

#### IMPORTANT:

- Before starting the connection, turn off the power of the devices to be connected.
- Procure screws (3 pcs.) to secure the camera to a ceiling or a wall, according to the material of the installation area. In this case, wood screws and nails should not be used.
- Required pull-out capacity of a single screw is 196 N {20 kgf} or more.

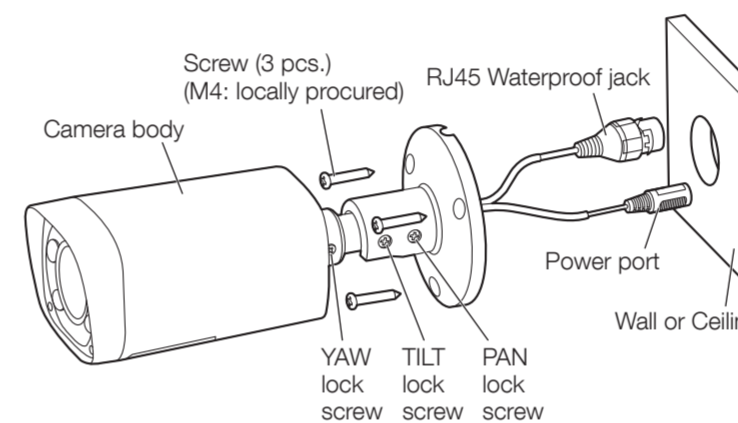

#### Step 1 Open a hole for installing the camera and cabling in the ceiling or wall.

Pick out the template from the carton box and use it to open holes in the positions for installation screws and the wiring opening to pass cabling through.

#### NOTE:

- To mount the camera on a wall, orient the template such that the camera can be secured in place using two of the three securing screws on the top. (See figure at right.)
- Determine the screw hole diameter based on screw specifications.
- To run cabling or make connections behind a ceiling or wall, drill a hole in the center position. If it is necessary to run the cabling to the side, it can be fed through the base in a direction. Orient the wiring connection direction to match the camera base.

#### Step 2 If necessary, install a micro SD memory card in the camera.

- Use a Phillips screwdriver to loosen two screws on the bottom of the camera. Then remove the lower cover.
- Insert the micro SD memory card into the micro SD memory card socket.
- Return the lower cover removed in step 1 above to its original position, and secure it in place.

#### NOTE:

- Be careful not to touch the wiring portion of the circuit board when you install the micro SD memory card.
- Insert the micro SD memory card with the side with printing facing up.

#### Step 3 Connect the camera.

Connect the RJ45 waterproof connector to the camera's RJ45 waterproof jack. (Refer to steps 4 and 5 in "Assembling RJ45 waterproof connector".) If necessary, also connect the plug of an AC adaptor for 12 V DC power to the power port.

#### Step 4 Installing the camera.

Use the torx wrench (accessory) to loosen the PAN/TILT lock screws (one each). Then secure the camera to the ceiling or wall with three screws (M4: locally procured) while panning and tilting the camera as shown in the figure at right.

#### NOTE:

After connection, push extra cabling through the hole in the ceiling or wall to adjust the length.

#### Step 5 Turn the power on and check the screen on the computer.

Turn on power from the 12 V DC power supply or PoE device and operate the camera. Check video from the camera on the computer screen and refer to "Network Configuration" on the right side of this document.

#### Step 6 Adjust the camera angle.

Adjust the camera angle as you check video on the computer screen. Turn the camera arm unit to adjust PAN, or move the camera itself to adjust TILT or YAW, as shown at upper right. Adjust Horizontal (PAN) angle, Vertical (TILT) angle and Azimuth (YAW) angle of the camera so that the camera sensor section faces the bottom of the monitoring screen. Finally, tighten the PAN/TILT/YAW lock screw to secure the camera's position. (Recommended tightening torque: 0.78 N·m {8 kgf·cm})

## Network Configuration

The IP addresses of all the cameras are the same when shipped from the factory (default IP 192.168.1.108), in order to make the camera get access to the network smoothly. Please plan the usable IP segment reasonably according to the actual network environment.

### Set user's password

When accessing the camera for the first time, it is necessary to set the password for the camera. (Default user name is "admin". There is no need to change this default user name.) There are two methods to set the password.

#### Method 1 (See Figure 1)

Double click the "ConfigTool.exe" in the DVD-ROM and open the "Config Tool". Check Uninitialized camera and click two [Initialize] buttons to set a password. Set the new password on the Device initialization window and click [next] button.

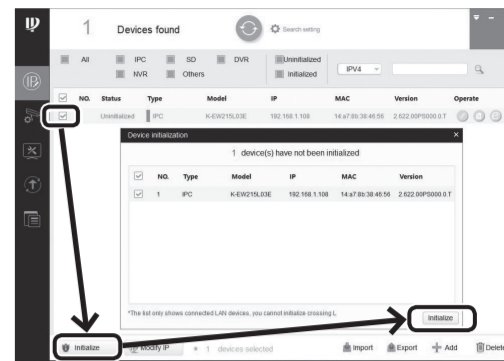

Figure 1 (In the case of Method 1)

#### Method 2 (See Figure 2)

Open IE and input the default IP address in the address bar, and directly access camera to set a password.

- For detail information about Method 2, refer to the WEB Operation Manual in the DVD-ROM.

#### IMPORTANT:

- Use a combination of characters and numbers that is difficult to guess.
- Be sure to manage the configured user names and passwords carefully.
- Change passwords periodically.

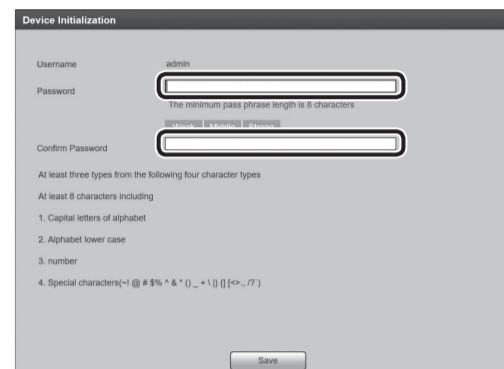

Figure 2 (In the case of Method 2)

### Modify IP Address

IP address can be acquired and modified through the "Config Tool" for the cameras which are accessed via wired network. This manual describes how to modify IP address via the "Config Tool". You can also modify the IP address in the network parameters of the web interface.

#### Step 1

Check a target camera and click [Search setting] button. (See Figure 3) Set the password on the Setting window and click [OK] button.

#### Step 2

Check a target camera and click [Modify IP] button to enter a new IP address. (See Figure 4) Set the new IP address on the Modify IP Address window and click [OK] button.

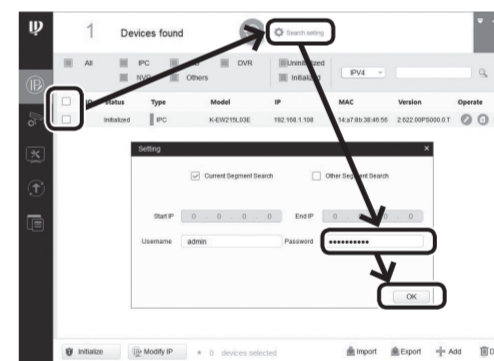

Figure 3

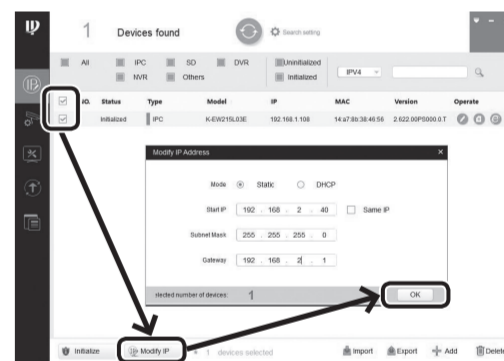

Figure 4

### Login WEB Interface

#### NOTE:

Different devices may have different web interfaces. The figure below is just for reference. Please refer to the document WEB Operation Manual in the DVD-ROM and the actual interface for more details.

#### Step 1

Select a camera in Device List in "ConfigTool" and click [e] mark to open the webpage.

#### Step 2

When the login interface is shown, input the password you set, and then click [login].

#### Step 3

The "Live" page will be displayed. (See Figure 5)



Figure 5

See support web page below for further details.  
<http://security.panasonic.com/pss/security/library/e-series.html>